

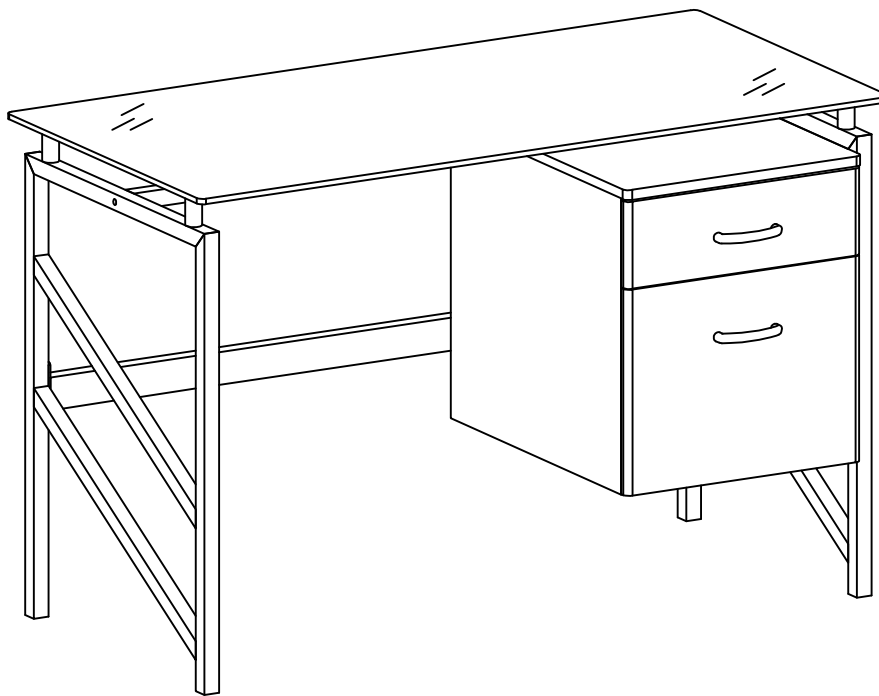

an LDI Company
Minneapolis, MN 55428
www.safcoproducts.com

Glass Top Desk w/ Metal Frame

Model No. 1006



PRODUCT WARRANTY is available online at: www.safcoproducts.com

• LA GARANTIE DU PRODUIT est
disponible sur l'Internet : www.safcoproducts.com

• LA GARANTÍA DEL PRODUCTO está
disponible en la Internet: www.safcoproducts.com



For questions or concerns, please call **1-888-971-6225**
available Monday-Friday 7:30 AM to 5:00 PM (Central Time) (English-speaking operators)

Si vous avez des questions pour poser ou les préoccupations
pour exprimer, connecter au **1-888-971-6225**
de 7H30 à 17H00 (Heure centrale) (Opérateurs de langue anglaise)

Si usted tiene preguntas o preocupaciones,
por favor llame **1-888-971-6225**
de 7:30 AM a 5:00 PM (Hora Central) (Operadores que hablan inglés)

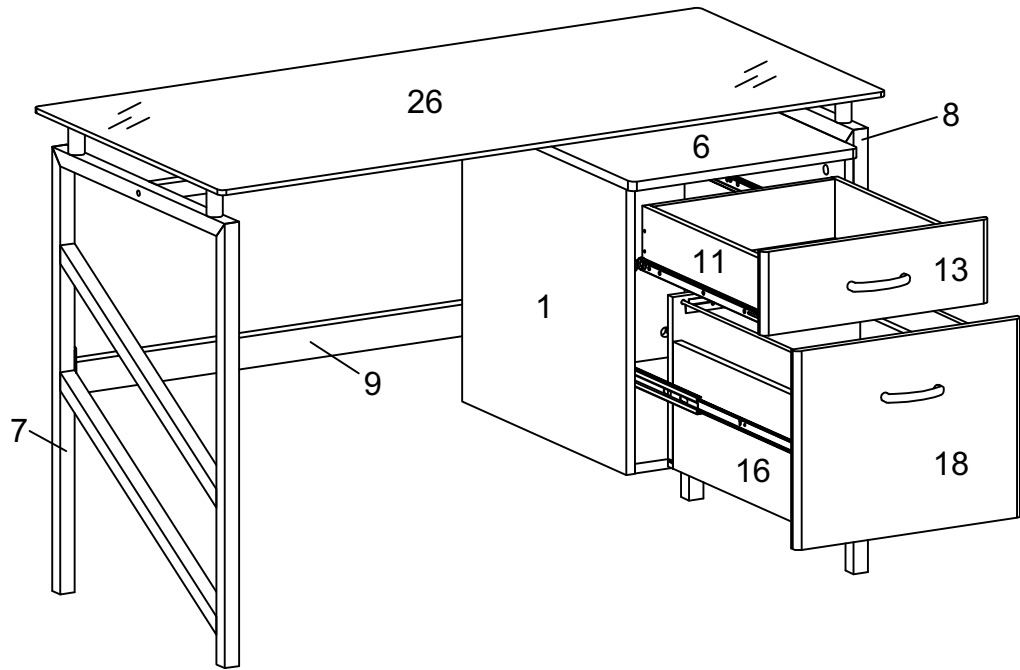

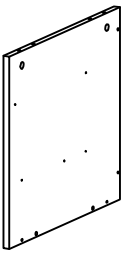
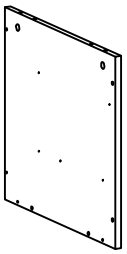
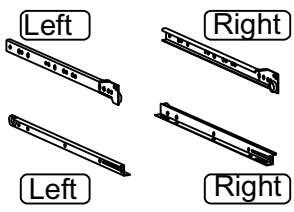
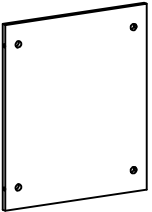
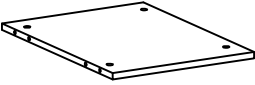
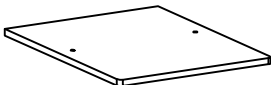
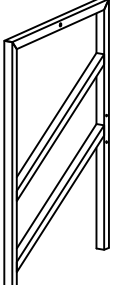
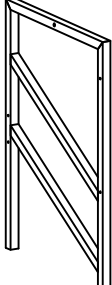

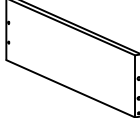
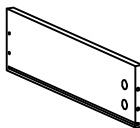

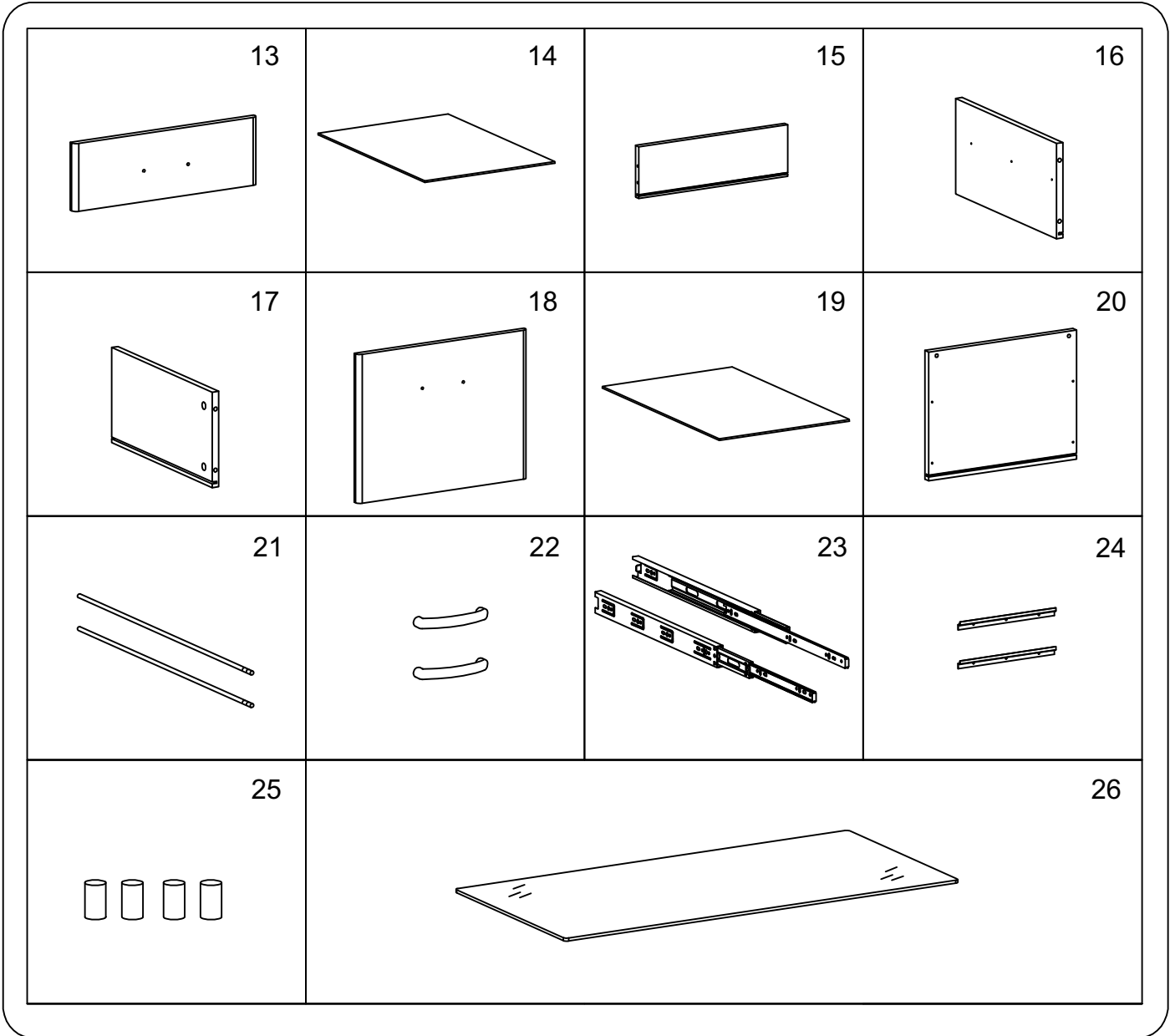



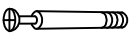

■PARTS LIST

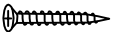

 <p>1</p>	 <p>2</p>	 <p>3</p>	 <p>4</p>
 <p>5</p>	 <p>6</p>	 <p>7</p>	 <p>8</p>
 <p>9</p>	 <p>10</p>	 <p>11</p>	 <p>12</p>

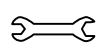

■ SCREWS LIST

PART	QTY.	ITEM		PART	QTY.	ITEM	
A	26	3x15 MM		G	4	6x45 MM	
B	20	6x40 MM		H	4	6x45 MM	
C	8	4x35 MM		I	4	Ø16 MM	
D	4	4x20 MM		J	2		
E	4	6x12 MM		K	2	6x30 MM	
F	5	6x35 MM			1		

*For Replacement Hardware Box order Part# 1006HB

Thanks for purchasing one of our products, please carefully read the assembly instructions before beginning the installation.

General Care:

-Keep your furniture out direct sunlight-Use desk pads and coasters to protect the surface from dents, scratches, and moisture from hot or cold liquids.

Cleaning:

-For cleaning, wipe the surface with a damp (not wet) cloth or wipe dry with a clean lint free cotton cloth.

-Window cleaning liquid or a similar cleaning liquid can be used to clean glass surface.

6x40MM BOLT INSTALLATION AS BELOW:

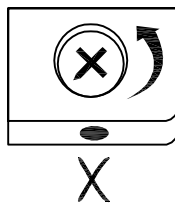
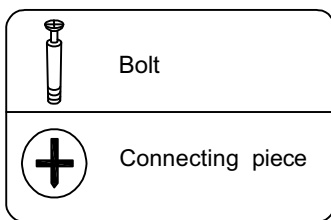

Adjust connecting piece direction if condition as illustrated

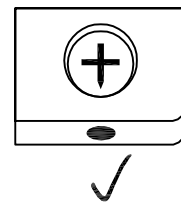

Insert bolt when Connecting piece under Such condition

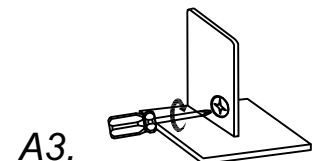
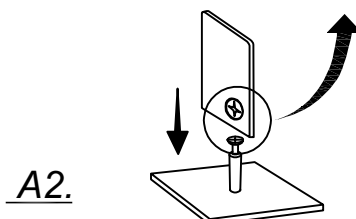
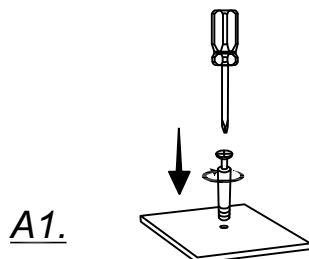

■ ASSEMBLY STEPS:

1

11 12 13

1 2 3

■ SCREWS

B 6x40 MM

4PCS

2

11 12 14

3

11 12 15

■ SCREWS

C 4x35 MM

4PCS

4

Left Right 3 11

■ SCREWS

A 3x15 MM

4PCS

5

11 13 22

■ SCREWS

D 4x20 MM

2PCS

6

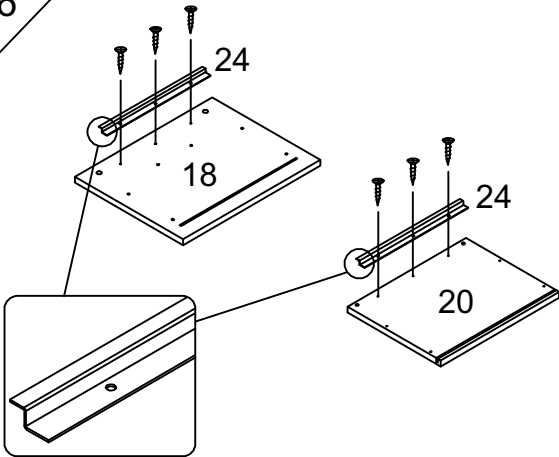

■ SCREWS

A 3x15 MM

6PCS



7

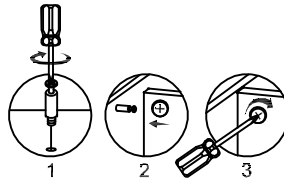
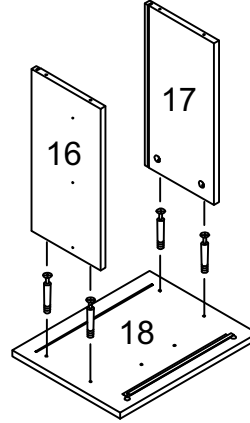

■ SCREWS

B 6x40 MM

4PCS



8

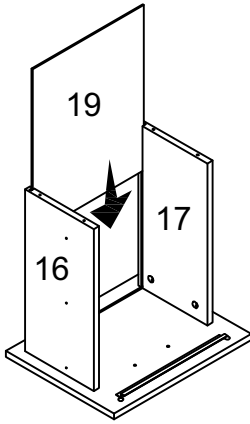

9

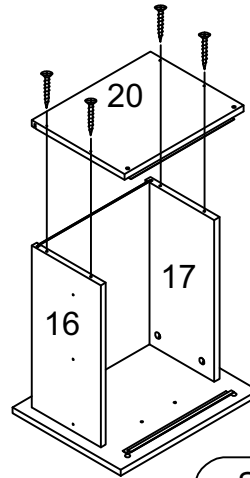

■ SCREWS

C 4x35 MM

4PCS



10

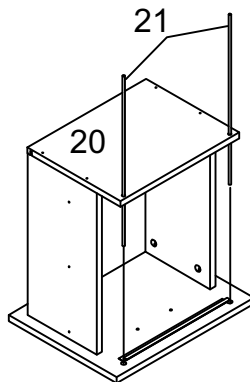

▲ Be careful not to overtighten the metal rod

11

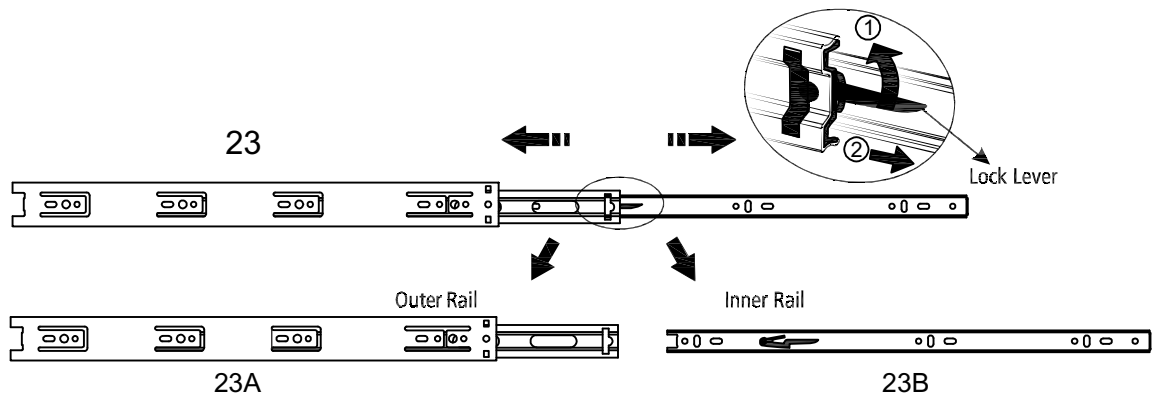

move the lock lever on the inner rail as shown and separate the outer rail (23a) and inner rail (23b) from the 2 file drawer slides (23)

12

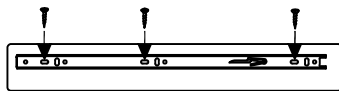
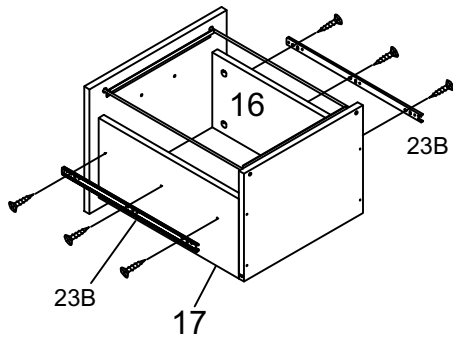

■ SCREWS

A 3x15 MM

6PCS



13

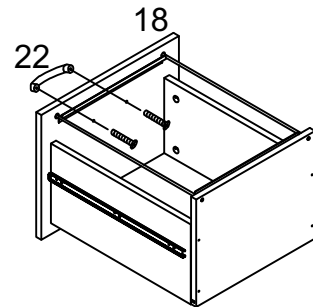

■ SCREWS

D 4x20 MM

2PCS



14

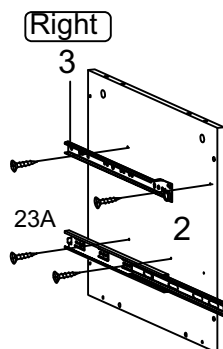
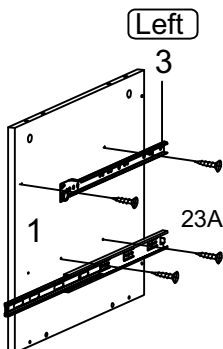
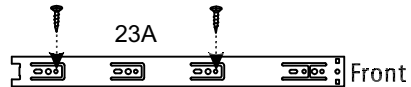
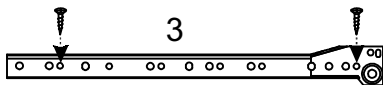

■ SCREWS

A 3x15 MM

8PCS



15

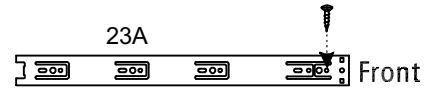
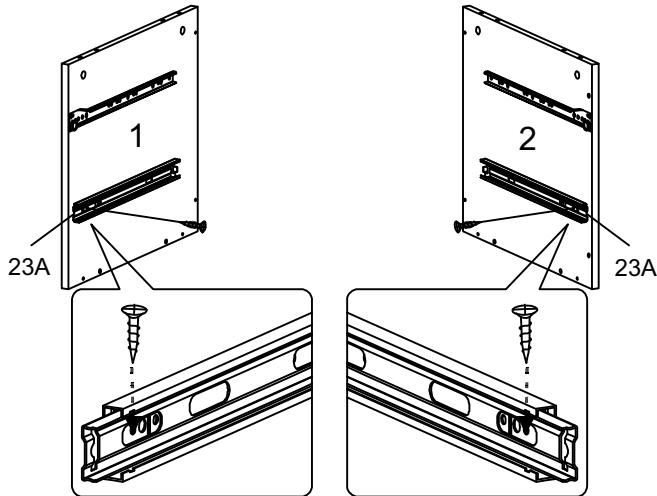

▪ SCREWS

A 3x15 MM

2PCS



16

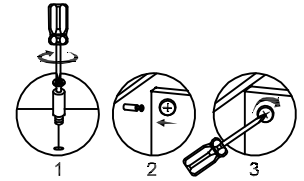
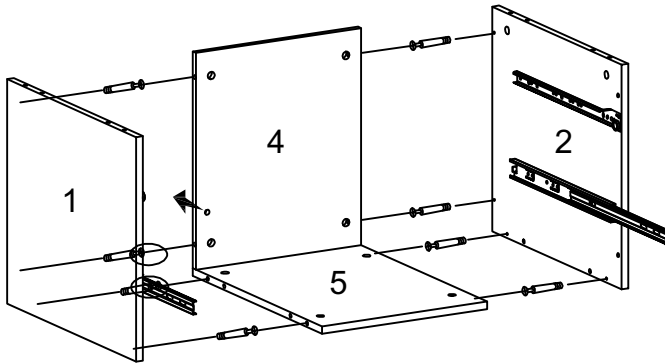

▪ SCREWS

B 6x0 MM

8PCS



17

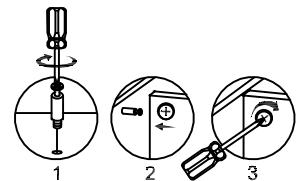
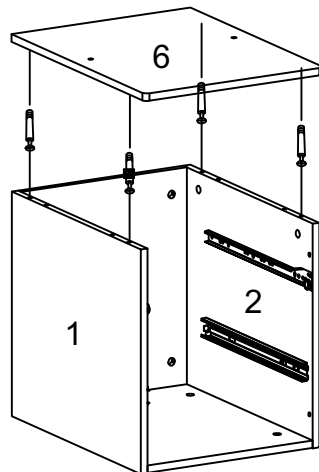

▪ SCREWS

B 6x40 MM

4PCS



18

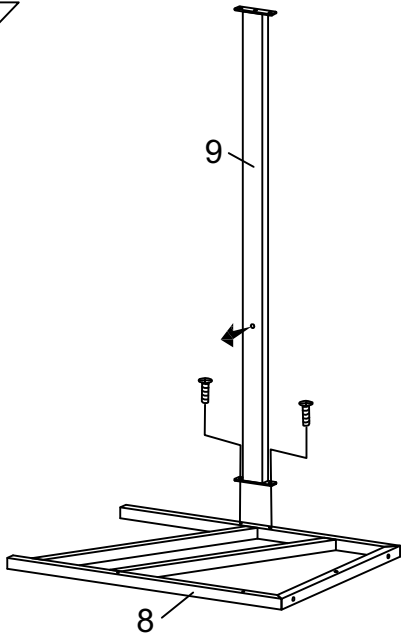

▪ SCREWS

E 6x12 MM
 2PCS



19

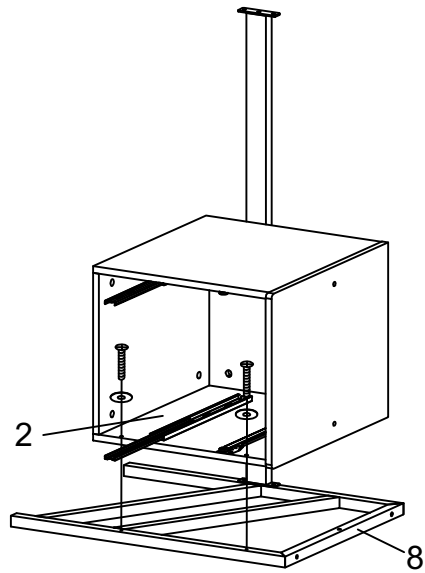

▪ SCREWS



K 6x30 MM
 2PCS

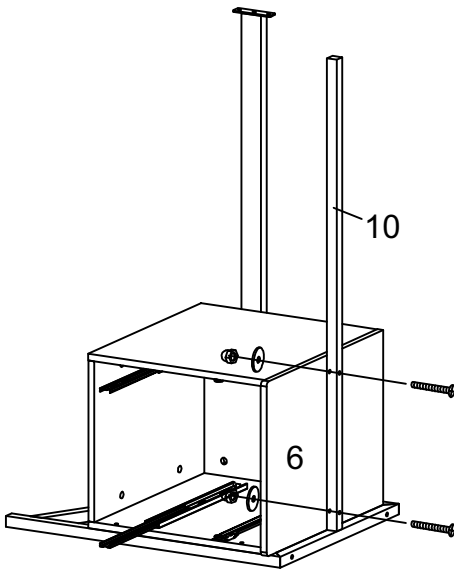

20





▪ SCREWS

G 6x45 MM  **I** Ø16 MM  2 PCS **J**  2 PCS

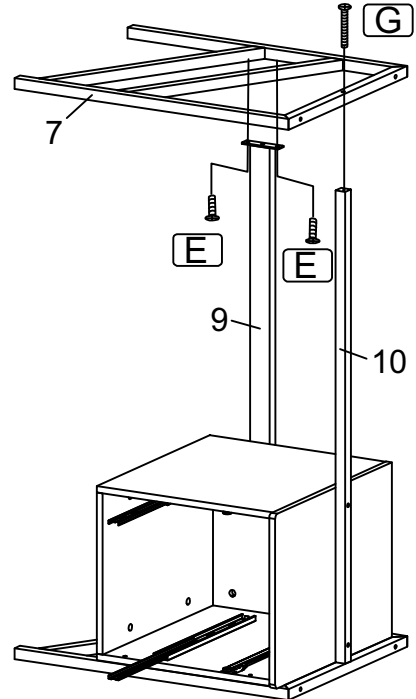
21



▪ SCREWS

E 6x12 MM  **G** 6x45 MM  1PC

22

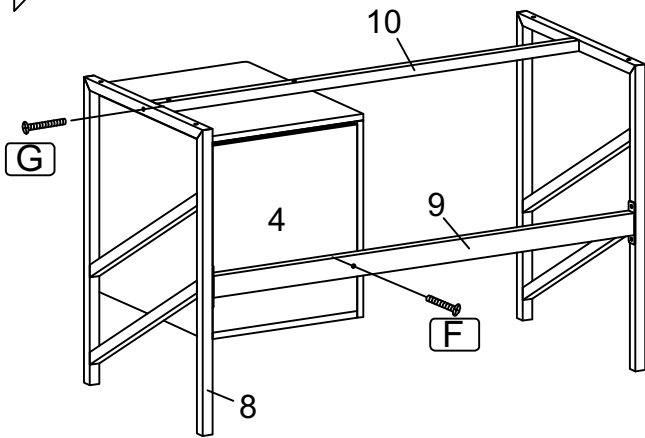

▪ SCREWS

F 6x35 MM

1PC



G 6x45 MM

1PC



23

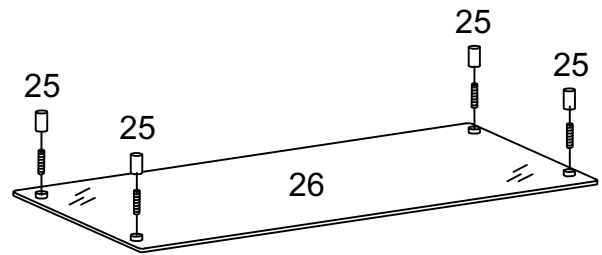

▪ SCREWS

H 6x20 MM

4PCS

24

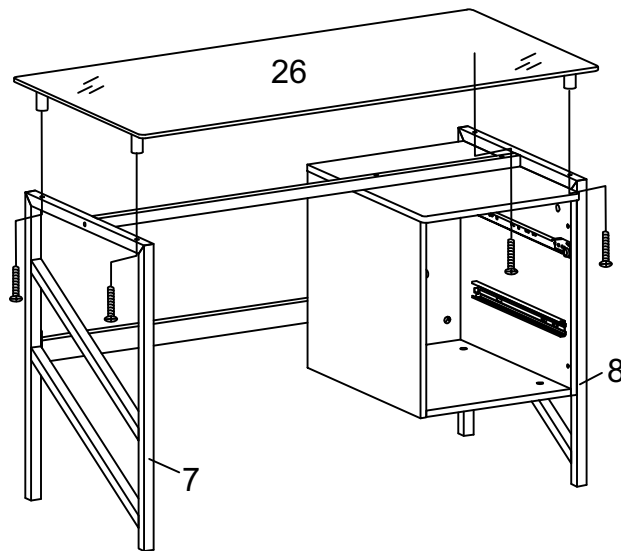

▪ SCREWS

F 6x35 MM

4PCS



25

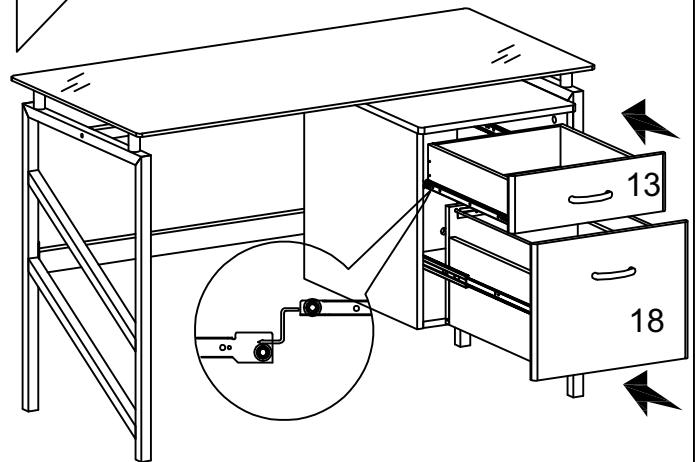

Make sure inner silver ball bearing slide is at the front of the slide mount and in lock position.

Align both sides of slide runners to slide mounts' openings, then slide all the way in. Apply small force to insert completely if needed.